

Series 31 compact cylinders

Double and single-acting, double-acting non-rotating, magnetic
 ø12, 16, 20, 25 mm
 ø 32, 40, 50, 63, 80, 100 mm UNITOP

SERIES 31 CYLINDERS



The compact dimensions allow Series 31 single and double-acting magnetic cylinders to be installed within confined spaces. These cylinders are suitable for use with feet, brackets.

These cylinders are available in 10 different bore sizes from ø 12 to ø 100. The guides are inserted in the external profile parallel to the sliding axis on three sides. These guides are used to locate the switches that sense the piston position. The construction design of these cylinders provides excellent axis stability. They are available either with a male or female thread. These cylinders can be supplied in W version for high temperatures (140°C). This last version is not magnetic.

- » Compact design
- » Wide range of models available
- » Standard magnetic
- » High temperature (double-acting and non magnetic)

GENERAL DATA

Type of construction	compact profile
Operation	single and double-acting
Materials	AL body and end-blocks - rolled stainless steel AISI 303 rod - AL piston rod PU seals or FKM seals for high temperatures (140°C)
Brackets	flange, feet, trunnion
Stroke min - max	Series 31R, 31M and 31F: ø12÷25 = 1÷200mm, ø32 ÷ 63 = 1÷300 mm, ø80÷100 = 1÷400mm The min. stroke for the use of sensors is 10 mm. Single-acting = 5÷25 mm (see the table of standard strokes)
Operating temperature	0°C ÷ 80°C (with dry air - 20°C)
Operating pressure	1 ÷ 10 bar (double-acting); 2 ÷ 10 bar (single-acting)
Fluid	filtered air, without lubrication. If lubricated air is used, it is recommended to use oil ISOVG32. Once applied the lubrication should never be interrupted.
Speed	10 ÷ 1000 mm/sec (without load)

STANDARD STROKES

■ = Double-acting female, male ✕ = Non-rotating ● = Single-acting female, male

STANDARD STROKES										
∅	5	10	15	20	25	30	40	50	60	80
12	■ ✕ ●	■ ✕ ●	■ ✕	■ ✕	■ ✕	■ ✕	■ ✕			
16	■ ✕ ●	■ ✕ ●	■ ✕ ●	■ ✕ ●	■ ✕ ●	■ ✕	■ ✕			
20	■ ✕ ●	■ ✕ ●	■ ✕ ●	■ ✕ ●	■ ✕ ●	■ ✕	■ ✕	■ ✕		
25	■ ✕ ●	■ ✕ ●	■ ✕ ●	■ ✕ ●	■ ✕ ●	■ ✕	■ ✕	■ ✕	■ ✕	
32	■ ✕ ●	■ ✕ ●	■ ✕ ●	■ ✕ ●	■ ✕ ●	■ ✕	■ ✕	■ ✕	■ ✕	
40	■ ✕ ●	■ ✕ ●	■ ✕ ●	■ ✕ ●	■ ✕ ●	■ ✕	■ ✕	■ ✕	■ ✕	■ ✕
50		■ ✕ ●	■ ✕ ●	■ ✕ ●	■ ✕ ●	■ ✕	■ ✕	■ ✕	■ ✕	■ ✕
63		■ ✕ ●	■ ✕ ●	■ ✕ ●	■ ✕ ●	■ ✕	■ ✕	■ ✕	■ ✕	■ ✕
80		■ ✕ ●	■ ✕ ●	■ ✕ ●	■ ✕ ●	■ ✕	■ ✕	■ ✕	■ ✕	■ ✕
100		■ ✕ ●	■ ✕ ●	■ ✕ ●	■ ✕ ●	■ ✕	■ ✕	■ ✕	■ ✕	■ ✕

CODING EXAMPLE

31	M	2	A	032	A	050	
31	SERIES 31 = compact magnetic						
M	VERSION M = male rod thread, mounted with rod nut Mod. U F = female rod thread R = non-rotating with flange only double-acting						
2	OPERATION 1 = single-acting, front spring 2 = double-acting 3 = double-acting, through-rod 4 = single-acting, rear spring 7 = single-acting, through-rod				PNEUMATIC SYMBOLS CS06 CD08 CD12 CS08 CS10		
A	MATERIALS A = rolled stainless steel AISI 303 rod - AL tube profile						
032	BORE 012 = 12 mm 016 = 16 mm 020 = 20 mm 025 = 25 mm 032 = 32 mm 040 = 40 mm 050 = 50 mm 063 = 63 mm 080 = 80 mm 100 = 100 mm						
A	DESIGN TYPE A = standard						
050	STROKE (see the table)						
	= standard V = rod seal FKM W = seals in FKM for high temperatures (140°C), only available in the double-acting, non magnetic version						

PNEUMATIC SYMBOLS

The pneumatic symbols which have been indicated in the CODING EXAMPLE are shown below.

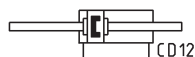

ACCESSORIES FOR COMPACT MAGNETIC CYLINDERS SERIES 31



Swivel ball joint Mod. GA
(cyl. Mod. 31M)



90° swivel combination
for trunnion Mod. I

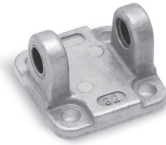

Rear trunnion Mod. C

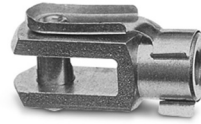

Rod fork end Mod. G
(cyl. Mod. 31M)



Piston rod lock nut
Mod. U (cyl. Mod. 31M)

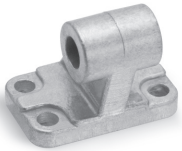

90° swivel combin. for
fem. trunnion Mod. ZC



Rear trunnion Mod. L



Rear and front flange
Mod. D



Foot mount Mod. B



Coupling piece
Mod. GKF



Self aligning rod
Mod. GK



Piston rod socket joint
Mod. GY (cyl. Mod. 31M)



All accessories are supplied separately.

ANTI-ROTATION - Transversal load dependant on projection

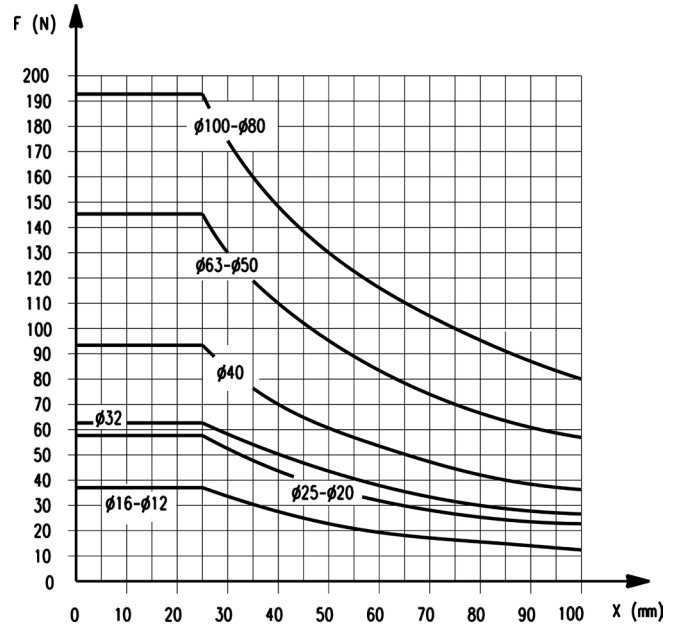
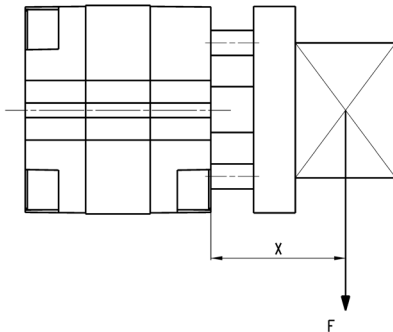

It is possible to determine the strokes required as shown in the general data in the absence of radial loads and torque moments. When imposing radial loads on the cylinder it is important to respect the maximum projection of the baricenter. In the presence of torque moments, it is recommended to respect the maximum stroke as shown in the diagrams.

ANTI-ROTATION THROUGH-ROD - Transversal load dependant on projection

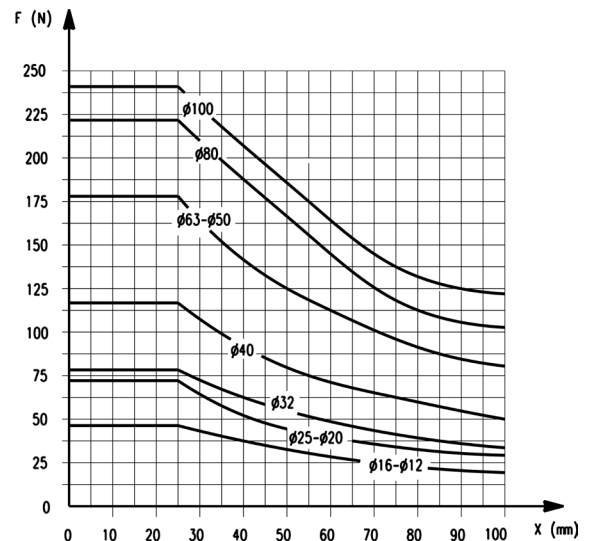
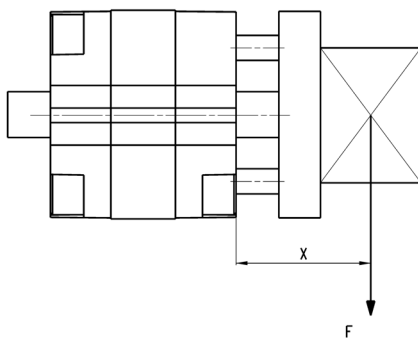

It is possible to determine the strokes required as shown in the general data in the absence of radial loads and torque moments. When imposing radial loads on the cylinder it is important to respect the maximum projection of the baricenter. In the presence of torque moments, it is recommended to respect the maximum stroke as shown in the diagrams.

TORQUE MOMENT - dependant on stroke C

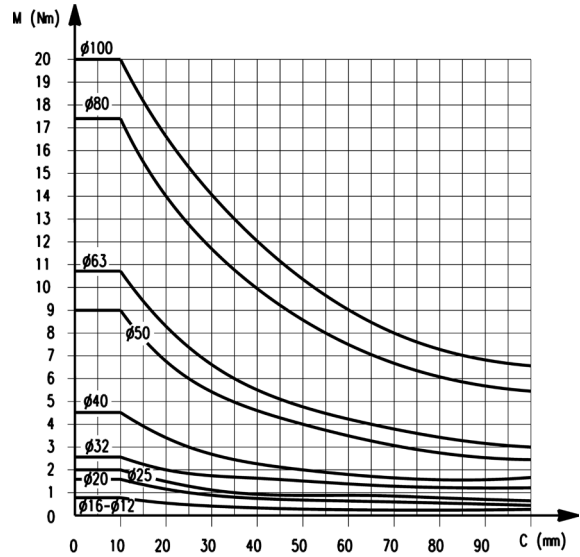
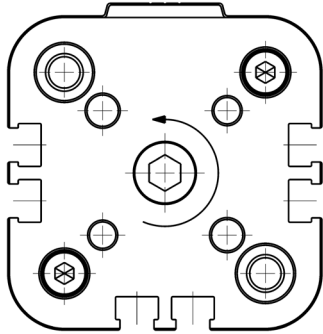

It is possible to determine the strokes required as shown in the general data in the absence of radial loads and torque moments. When imposing radial loads on the cylinder it is important to respect the maximum projection of the baricenter. In the presence of torque moments, it is recommended to respect the maximum stroke as shown in the diagrams.

TRANSVERSAL LOAD - dependant on projection

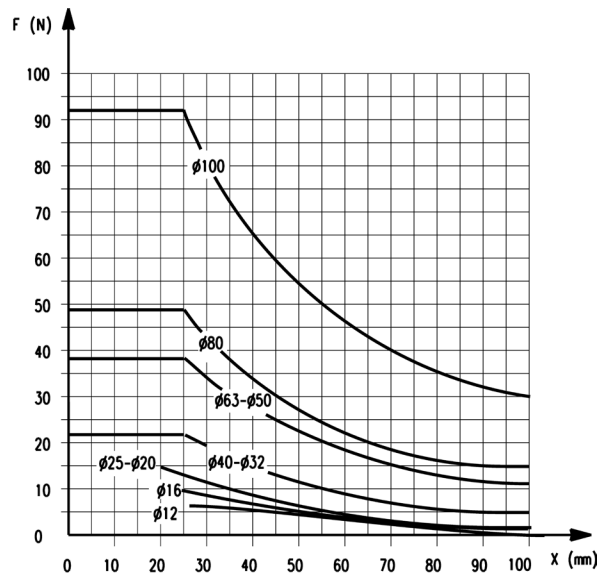
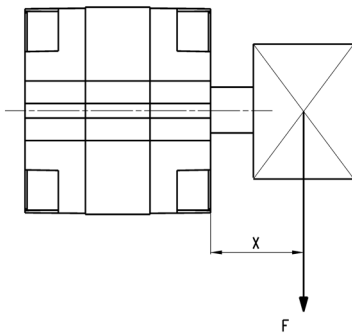

It is possible to determine the strokes required as shown in the general data in the absence of radial loads and torque moments. When imposing radial loads on the cylinder it is important to respect the maximum projection of the baricenter. In the presence of torque moments, it is recommended to respect the maximum stroke as shown in the diagrams.

TRANSVERSAL LOAD THROUGH-ROD - dependant on projection

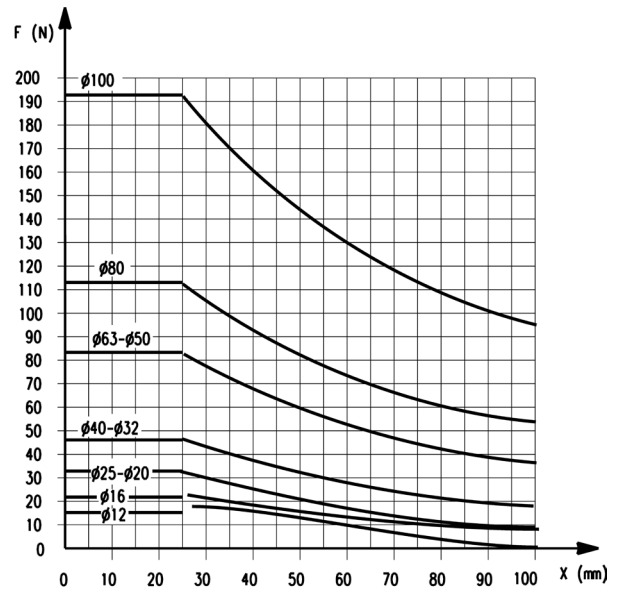
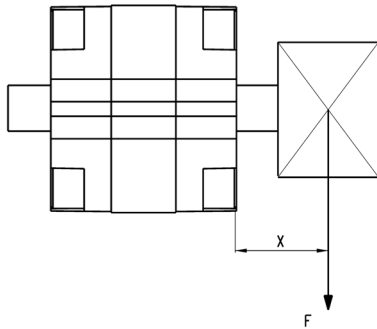

It is possible to determine the strokes required as shown in the general data in the absence of radial loads and torque moments. When imposing radial loads on the cylinder it is important to respect the maximum projection of the baricenter. In the presence of torque moments, it is recommended to respect the maximum stroke as shown in the diagrams.

Compact magnetic cylinders Mod. 31F and 31M



1 = Groove for sensor CST
2 = Keep to the minimum screwing depth.
+ = add the stroke

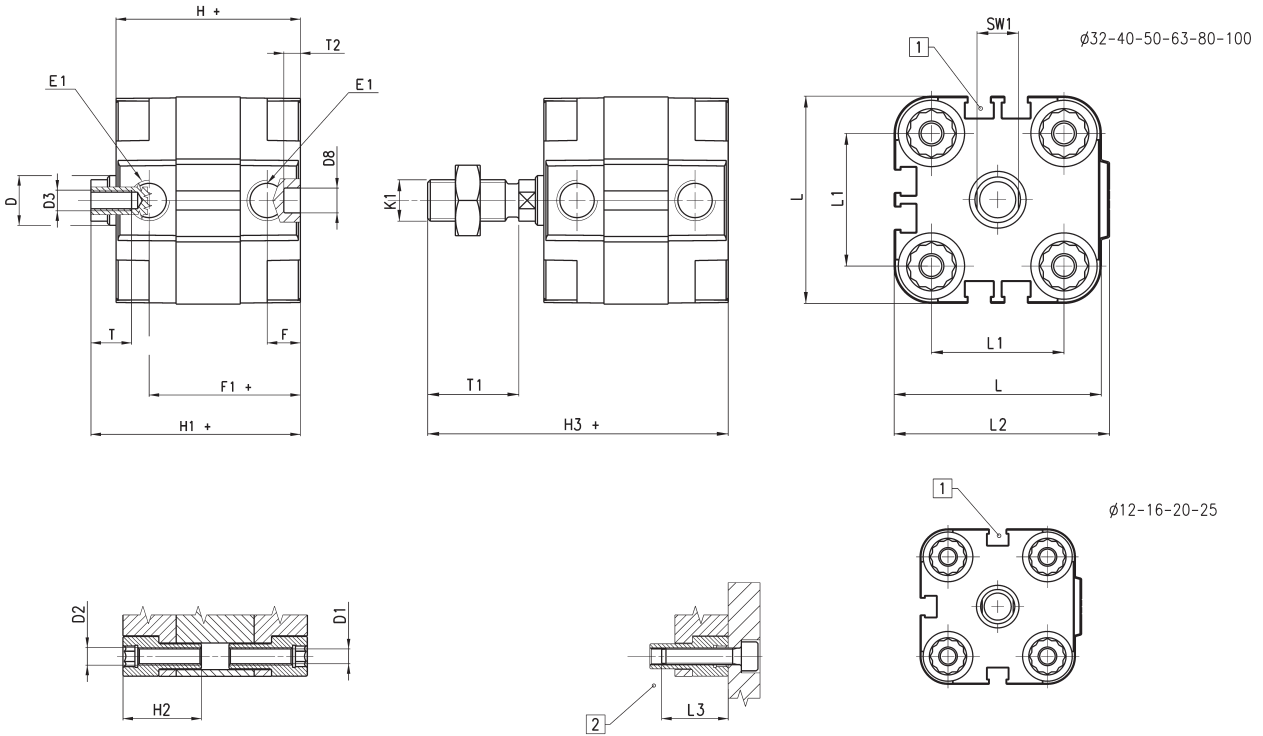

DIMENSIONS																					
Ø	øD	øD1	D2	D3	øD8 ^(H9)	E1	F	F1+	H+	H1+	H2	H3+	K1	L	L1	L2	L3	T	T1	T2	SW1
12	6	3,5	M4	M3	6	M5	8	30	38	42,5	18,5	58,5	M6	29	18	30	16	6	16	4	5
16	8	3,5	M4	M4	6	M5	8	30	38	42,5	18,5	62,5	M8	29	18	30	16	8	20	4	7
20	10	4,5	M5	M5	6	M5	8	30	38	42,5	18,5	64,5	M10x1,25	36	22	37,5	18	10	22	4	8
25	10	4,5	M5	M5	6	M5	8	31,5	39,5	45	18,5	67	M10x1,25	40	26	41,5	18	10	22	4	8
32	12	5,5	M6	M6	6	G1\8	8	36,5	44,5	50,5	21,5	72,5	M10x1,25	50	32	52	20	12	22	4	10
40	12	5,5	M6	M6	6	G1\8	8	37,5	45,5	52	21,5	74	M10x1,25	60	42	62,5	20	12	22	4	10
50	16	6,5	M8	M8	6	G1\8	8	37,5	45,5	53	22,5	77	M12x1,25	68	50	71	20	12	24	4	13
63	16	8,5	M10	M8	8	G1\8	8	42	50	57,5	24,5	81,5	M12x1,25	87	62	91	25	12	24	4	13
80	20	8,5	M10	M10	8	G1\8	8,5	47,5	56	64	24,5	96	M16x1,5	107	82	111	25	16	32	4	17
100	25	8,5	M10	M12	8	G1\4	10,5	56	66,5	76,5	31,5	116,5	M20x1,5	128	103	133	25	20	40	4	22

Compact magnetic cylinders Mod. 31F and 31M - through-rod



- 1 = Groove for sensor CST
- 2 = Keep to the minimum screwing depth.
- + = add the stroke once
- ++ = add the stroke twice

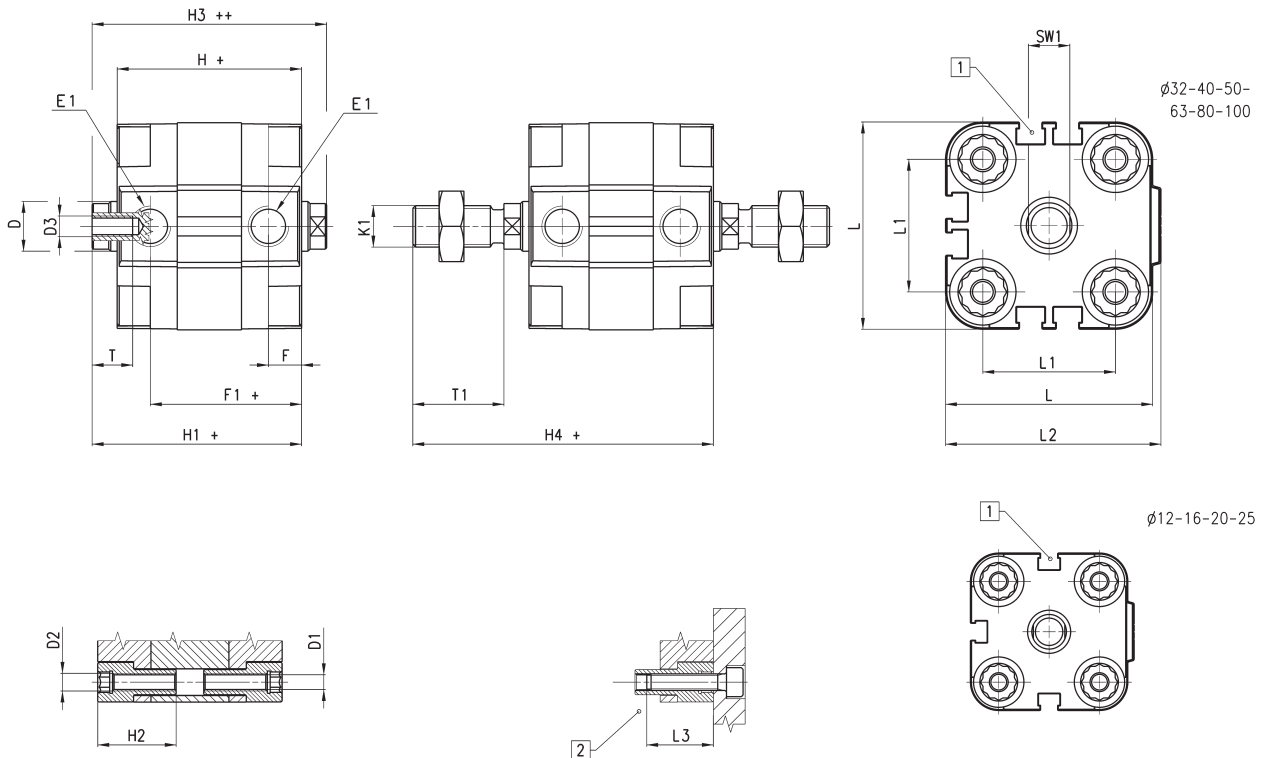

DIMENSIONS																				
\emptyset	$\emptyset D$	$\emptyset D1$	D2	D3	E1	F	F1+	H+	H1+	H2	H3++	H4+	K1	L	L1	L2	L3	T	T1	SW1
12	6	3,5	M4	M3	M5	8	30	38	42,5	18,5	47	58,5	M6	29	18	30	16	6	16	5
16	8	3,5	M4	M4	M5	8	30	38	42,5	18,5	47	62,5	M8	29	18	30	16	8	20	7
20	10	4,5	M5	M5	M5	8	30	38	42,5	18,5	47	64,5	M10x1,25	36	22	37,5	18	10	22	8
25	10	4,5	M5	M5	M5	8	31,5	39,5	45	18,5	50,5	67	M10x1,25	40	26	41,5	18	10	22	8
32	12	5,5	M6	M6	G1\8	8	36,5	44,5	50,5	21,5	56,5	72,5	M10x1,25	50	32	52	20	12	22	10
40	12	5,5	M6	M6	G1\8	8	37,5	45,5	52	21,5	58,5	74	M10x1,25	60	42	62,5	20	12	22	10
50	16	6,5	M8	M8	G1\8	8	37,5	45,5	53	22,5	60,5	77	M12x1,25	68	50	71	20	12	24	13
63	16	8,5	M10	M8	G1\8	8	42	50	57,5	24,5	65	81,5	M12x1,25	87	62	91	25	12	24	13
80	20	8,5	M10	M10	G1\8	8,5	47,5	56	64	24,5	72	96	M16x1,5	107	82	111	25	16	32	17
100	25	8,5	M10	M12	G1\4	10,5	56	66,5	76,5	31,5	86,5	116,5	M20x1,5	128	103	133	25	20	40	22

Compact magnetic cylinders Mod. 31R



1 = Groove for sensor CST
 2 = Keep to the minimum screwing depth.
 += add the stroke once
 ++ = add the stroke twice

SERIES 31 CYLINDERS

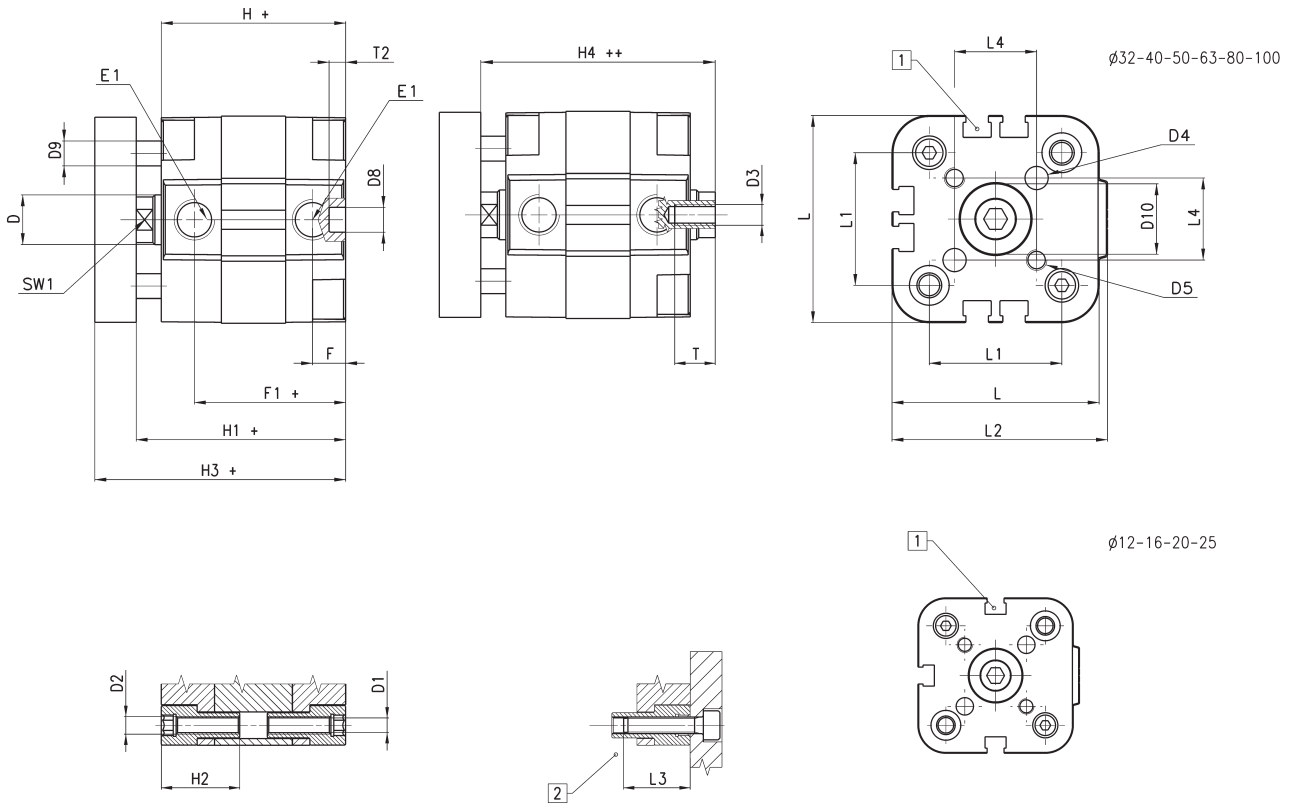

DIMENSIONS																									
Ø	øD	øD1	D2	D3	øD4 ^(H9)	D5	D8 ^(H9)	øD9	D10	E1	F	F1+	H+	H1+	H2	H3+	H4++	L	L1	L2	L3	L4	T	T2	SW1
12	6	3,5	M4	M3	3	M3	6	5	6	M5	8	30	38	42,5	18,5	48,5	47	29	18	30	16	9,9	6	4	5
16	8	3,5	M4	M4	3	M3	6	5	8	M5	8	30	38	42,5	18,5	48,5	47	29	18	30	16	9,9	8	4	7
20	10	4,5	M5	M5	4	M4	6	6	10	M5	8	30	38	42,5	18,5	50,5	47	36	22	37,5	18	12	10	4	8
25	10	4,5	M5	M5	5	M5	6	6	14	M5	8	31,5	39,5	45	18,5	53	50,5	40	26	41,5	18	15,6	10	4	8
32	12	5,5	M6	M6	5	M5	6	6	17	G1/8	8	36,5	44,5	50,5	21,5	60,5	56,5	50	32	52	20	19,8	12	4	10
40	12	5,5	M6	M6	5	M5	6	6	17	G1/8	8	37,5	45,5	52	21,5	62	58,5	60	42	62,5	20	23,3	12	4	10
50	16	6,5	M8	M8	6	M6	6	10	22	G1/8	8	37,5	45,5	53	22,5	65	60,5	68	50	71	20	29,7	12	4	13
63	16	8,5	M10	M8	6	M6	8	10	22	G1/8	8	42	50	57,5	24,5	69,5	65	87	62	91	25	35,4	12	4	13
80	20	8,5	M10	M10	8	M8	8	12	28	G1/8	8,5	47,5	56	64	24,5	78	72	107	82	111	25	46	16	4	17
100	25	8,5	M10	M12	10	M10	8	12	30	G1/4	10,5	56	66,5	76,5	31,5	90,5	86,5	128	103	133	25	56,6	20	4	22

Foot mount Mod. B

Material: zinc-plated steel



Supplied with:
2x feet
4x screws
+ = add the stroke

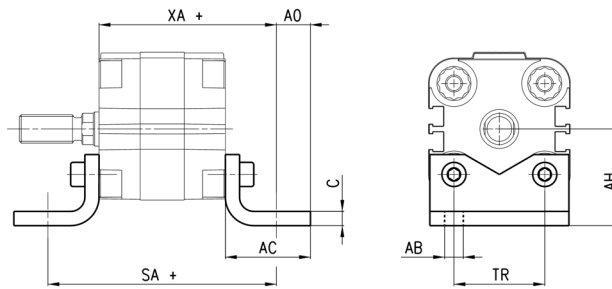

DIMENSIONS									
Mod.	∅	C	SA+	XA+	TR	AB	AH	AO	AC
B-31-12-16	12 - 16	3	64	51	18	5,5	22	7	20
B-32-20	20	4	70	54	22	6,6	27	9	25
B-31-25	25	4	71,5	55,5	26	6,6	29	9	25
B-31-32	32	5	80,5	62,5	32	6,6	34	12	30
B-31-40	40	5	85,5	65,5	42	9	40,5	10	30
B-31-50	50	5,5	93,5	69,5	50	9	47	11	35
B-31-63	63	5,5	104	77	62	11	56,5	13	40
B-31-80	80	7,5	116	86	82	11	68,5	15	45
B-31-100	100	7,5	132,5	99,5	103	13,5	81	12	45

Rear and front flange Mod. D-E

Material: zinc-plated steel



Supplied with:
1x flange
4x screws
+ = add the stroke

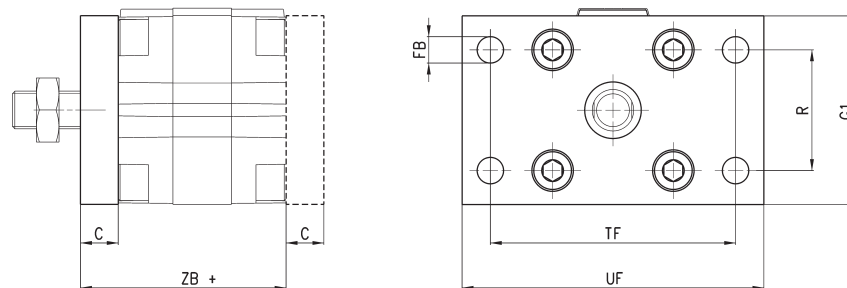

DIMENSIONS								
Mod.	∅	C	ZB+	TF	R	UF	G1	FB
D-E-31-12-16	12 - 16	10	48	43	-	55	29	5,5
D-E-32-20	20	10	48	55	-	70	36	6,6
D-E-32-25	25	10	49,5	60	-	76	40	6,6
D-E-31-32	32	10	54,5	65	32	80	50	7
D-E-31-40	40	10	55,5	82	36	102	60	9
D-E-31-50	50	12	57,5	90	45	110	68	9
D-E-31-63	63	15	65	110	50	130	87	9
D-E-31-80	80	15	71	135	63	160	107	12
D-E-31-100	100	15	81,5	163	75	190	128	14

Female rear trunnion Mod. C

Material: Aluminium



Supplied with:
4x screws
1x clevis pin
1x centering pin
1x trunnion
+ = add the stroke

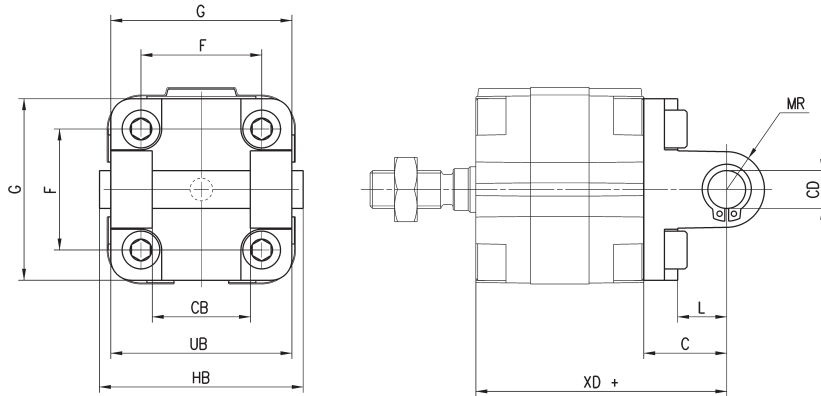

DIMENSIONS											
Mod.	∅	∅CD	L	C	XD+	MR	F	G	CB	UB	HB
C-31-32	32	10	13	21	66,5	11	32	50	26	45	54
C-31-40	40	12	16	25	70,5	13	42	60	28	52	62
C-31-50	50	12	16	27	72,5	13	50	68	32	60	70
C-31-63	63	16	21	32	82	17	62	87	40	70	82
C-31-80	80	16	23	36	92	17	82	102	50	90	102
C-31-100	100	20	26	41	107,5	21	103	128	60	110	126

Intermediate bracket Mod. DC

Flange in aluminium



Supplied with:
1x flange
1x centering pin
4x screws

+ = add the stroke

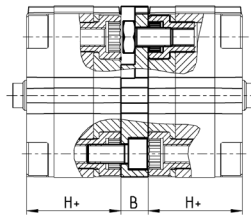

DIMENSIONS				
Mod.	∅	B	H+	Max stroke (mm)
DC-31-12-16	12-16	12,5	38	400
DC-31-20	20	12,5	38	400
DC-31-25	25	13	39,5	400
DC-31-32	32	14,5	44,5	600
DC-31-40	40	14,5	45,5	600
DC-31-50	50	14,5	45,5	600
DC-31-63	63	14,5	50	600
DC-31-80	80	16,5	56	800
DC-31-100	100	19,5	66,5	800

90° Swivel combination for female trunnion Mod. ZC

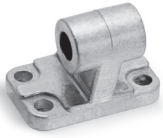

Male rear
Material: aluminium

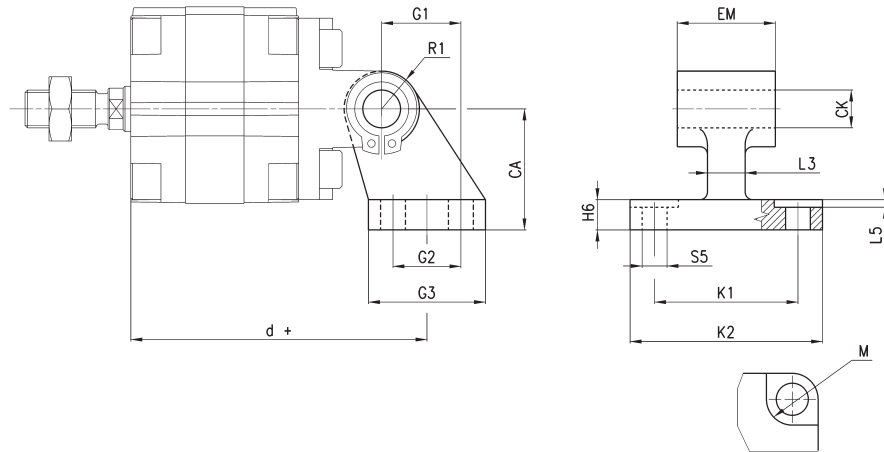

Supplied with:
1x male support

+ = add the stroke

DIMENSIONS																
Mod.	∅	M	∅CK	∅S5	d+	K1	K2	L3	G1	L5	G2	EM	G3	CA	H6	R1
ZC-32	32	11	10	6,6	78,5	38	51	10	21	1,6	18	26	31	32	8	10
ZC-40	40	11	12	6,6	83,5	41	54	15	24	1,6	22	28	35	36	10	11
ZC-50	50	15	12	9	90,5	50	65	16	33	1,6	30	32	45	45	12	13
ZC-63	63	15	16	9	101,5	52	67	16	37	1,6	35	40	50	50	14	15
ZC-80	80	18	16	11	119	66	86	20	47	2,5	40	50	60	63	14	15
ZC-100	100	18	20	11	137,5	76	96	20	55	3,2	50	60	70	71	17	19

90° swivel combination for trunnion Mod. I



Material: zinc-plated steel

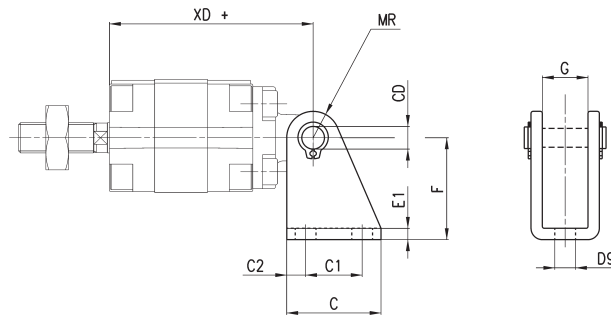

Supplied with:
2x Seeger
1x female support
1x piston pin

+ = add the stroke

DIMENSIONS											
Mod.	∅	∅CD	C	C1	∅C2	XD+	MR	∅D9	E1	F	G
I-12-16	12	6	25	15	5	54	7	5,5	3	27	12,1
I-12-16	16	6	25	15	5	54	7	5,5	3	27	12,1
I-20-25	20	8	32	20	6	58	10	6	4	30	16,1
I-20-25	25	8	32	20	6	59,5	10	6	4	30	16,1

Rear male trunnion Mod. L



Material: aluminium
Supplied with:
4x screws
1x male trunnion
1x centering pin

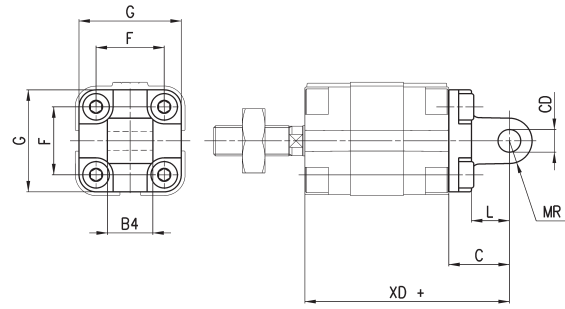

DIMENSIONS									
	∅	_e CD	L	C	XD+	MR	F	G	B4
L-31-12-16	12	6	10	16	54	6	18	30	12
L-31-12-16	16	6	10	16	54	6	18	30	12
L-31-20	20	8	14	20	58	8	22	37,5	16
L-31-25	25	8	14	20	59,5	8	26	41,5	16

+ = add the stroke

Piston rod lock nut Mod. U



Material: zinc-plated steel
ISO 4035

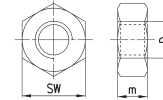

DIMENSIONS				
Mod.	∅ cylinder	D	m	SW
U-12-16	12	M6X1	4	10
U-20	16	M8X1,25	5	13
U-25-32	20-40	M10X1,25	6	17
U-40	50-63	M12X1,25	7	19
U-50-63	80	M16X1,5	8	24
U-80-100	100	M20X1,5	9	30

Swivel ball joint Mod. GA



Material: zinc-plated steel
ISO 8139

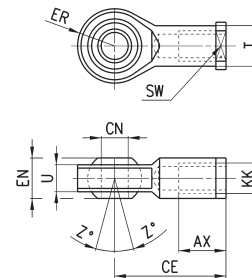

DIMENSIONS											
Mod.	∅	_e CN	U	EN	ER	AX	CE	KK	T	Z	SW
GA-12-16	12	6	7	9	10	12	30	M6X1	10	6,5	11
GA-20	16	8	9	12	12	16	36	M8X1,25	12,5	6,5	14
GA-32	20÷40	10	10,5	14	14	20	43	M10X1,25	15	6,5	17
GA-40	50÷63	12	12	16	16	22	50	M12X1,25	17,5	6,5	19
GA-50-63	80	16	15	21	21	28	64	M16X1,5	22	7,5	22
GA-80-100	100	20	18	25	25	33	77	M20X1,5	27,5	7	30

Rod fork end Mod. G

ISO 8140
Material: zinc-plated steel

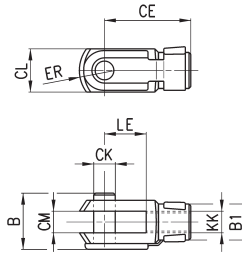
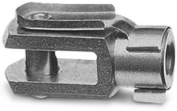

DIMENSIONS										
Mod.	∅	B	\varnothing_{B1}	\varnothing_{CK}	LE	CM	CL	ER	CE	KK
G-12-16	12	16	10	6	12	6	12	7	24	M6X1
G-20	16	22	14	8	16	8	16	42	32	M8X1,25
G-25-32	20 ÷ 40	26	18	10	20	10	20	12	40	M10X1,25
G-40	50 ÷ 63	32	20	12	24	12	24	14	48	M12X1,25
G-50-63	80	40	26	16	32	16	32	19	64	M16X1,5
G-80-100	100	48	34	20	40	20	40	25	80	M20X1,5

Piston rod socket joint Mod. GY

Material: zama and zinc-plated steel

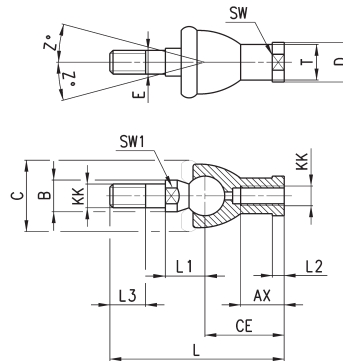

DIMENSIONS																
Mod.	∅	KK	L	CE	L2	AX	E	\varnothing_B	\varnothing_C	\varnothing_T	\varnothing_D	L1	L3	SW1	SW	Z
GY-12-16	12	M6X1	55	28	5	15	6	10	20	10	13	12,2	11	8	11	15
GY-20	16	M8X1,25	65	32	5	16	8	12	24	12,5	16	16	12	10	14	15
GY-32	20÷40	M10X1,25	74	35	6,5	18	10	14	28	15	19	19,5	15	11	17	15
GY-40	50÷63	M12X1,25	84	40	6,5	20	12	19	32	17,5	22	21	17	17	19	15
GY-50-63	80	M16X1,5	112	50	8	27	16	22	40	22	27	27,5	23	19	22	11
GY-80-100	100	M20X1,5	133	63	10	38	20	27	45	27,5	34	31,5	25	24	30	7,5

Self aligning rod Mod. GK

For cylinders with male rod only.

Material: zinc-plated steel

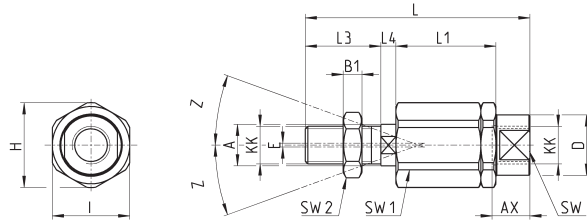

DIMENSIONS																	
Mod.	∅	KK	L	L1	L3	L4	∅ A	∅ D	H	I	SW	SW1	SW2	B1	AX	Z	E
GK-20	16	M8x1,25	57	26	21	5	8	12,5	19	17	11	7	13	4	16	4	2
GK-25-32	20-25-32-40	M10x1,25	71,5	35	20	7,5	14	22	32	30	19	12	17	5	22	4	2
GK-40	50-63	M12x1,25	75,5	35	24	7,5	14	22	32	30	19	12	19	6	22	4	2
GK-50-63	80	M16x1,5	104	53	32	10	22	32	45	41	27	20	24	8	30	3	2
GK-80-100	100	M20x1,5	119	53	40	10	22	32	45	41	27	20	30	10	37	3	2

Coupling piece Mod. GKF

Material: zinc-plated steel

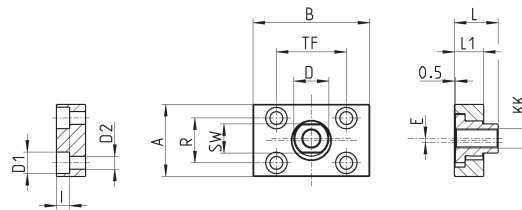
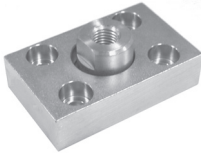

DIMENSIONS														
Mod.	∅	KK	A	B	R	TF	L	L1	I	∅ D	∅ D1	∅ D2	SW	E
GKF-20	16	M8x1,25	30	35	20	25	22,5	10	-	14	5,5	-	13	1,5
GKF-25-32	20-25-32-40	M10x1,25	37	60	23	36	22,5	15	6,8	18	11	6,6	15	2
GKF-40	50-63	M12x1,25	56	60	38	42	22,5	15	9	20	15	9	15	2,5
GKF-50-63	80	M16x1,5	80	80	58	58	26,5	15	10,5	25	18	11	22	2,5
GKF-80-100	100	M20x1,5	90	90	65	65	32,5	20	13	30,5	20	14	27	2,5